

# FAN7532 Ballast Control IC

## Features

- Floating Channel Designed for Bootstrap Operation to +600V
- Lower di/dt Gate Driver for Better Noise Immunity
- Driver Current Capability: 250mA/500mA (Typ.)
- Low Start-up and Operating Current: 120µA, 6.4mA
- Under-Voltage Lockout (UVLO) with 1.8V of Hysteresis
- Programmable Preheat Time and Frequency
- Programmable Run Frequency
- Protection from Failure to Strike
- Lamp Filament Sensing and Protection
- Automatic Restart for Lamp Exchange
- High-Accuracy Oscillator
- 16-Pin SOP

## Applications

- General Purpose Ballast IC

## Description

The FAN7532 provides simple and high-performance electronic ballast control functions. Optimized for an electronic ballast, the FAN7532 requires a minimum board area and reduces component counts. The FAN7532 is intended to drive two power MOSFETs in the classical half-bridge topology with all the features needed to properly drive and control a fluorescent lamp. The FAN7532 has many comprehensive protection features that work through filament failure, failure of a lamp to strike, and automatic restarts. A dedicated timing section in the FAN7532 allows the user to set the necessary parameters to preheat, ignite, and run the lamp properly.

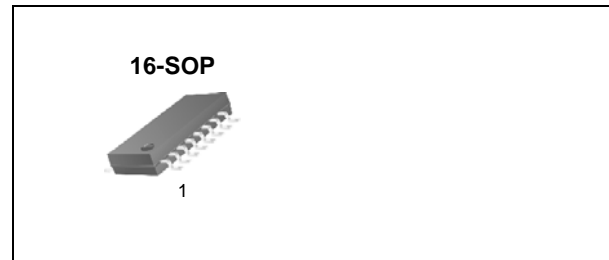

## Ordering Information

Part Number	Package	Pb-Free	Operating Temperature Range	Packing Method
FAN7532M	16-SOP	Yes	-25°C ~ 125°C	TUBE
FAN7532MX				TAPE & REEL

FPS™ is a trademark of Fairchild Semiconductor Corporation.

Typical Application Circuit

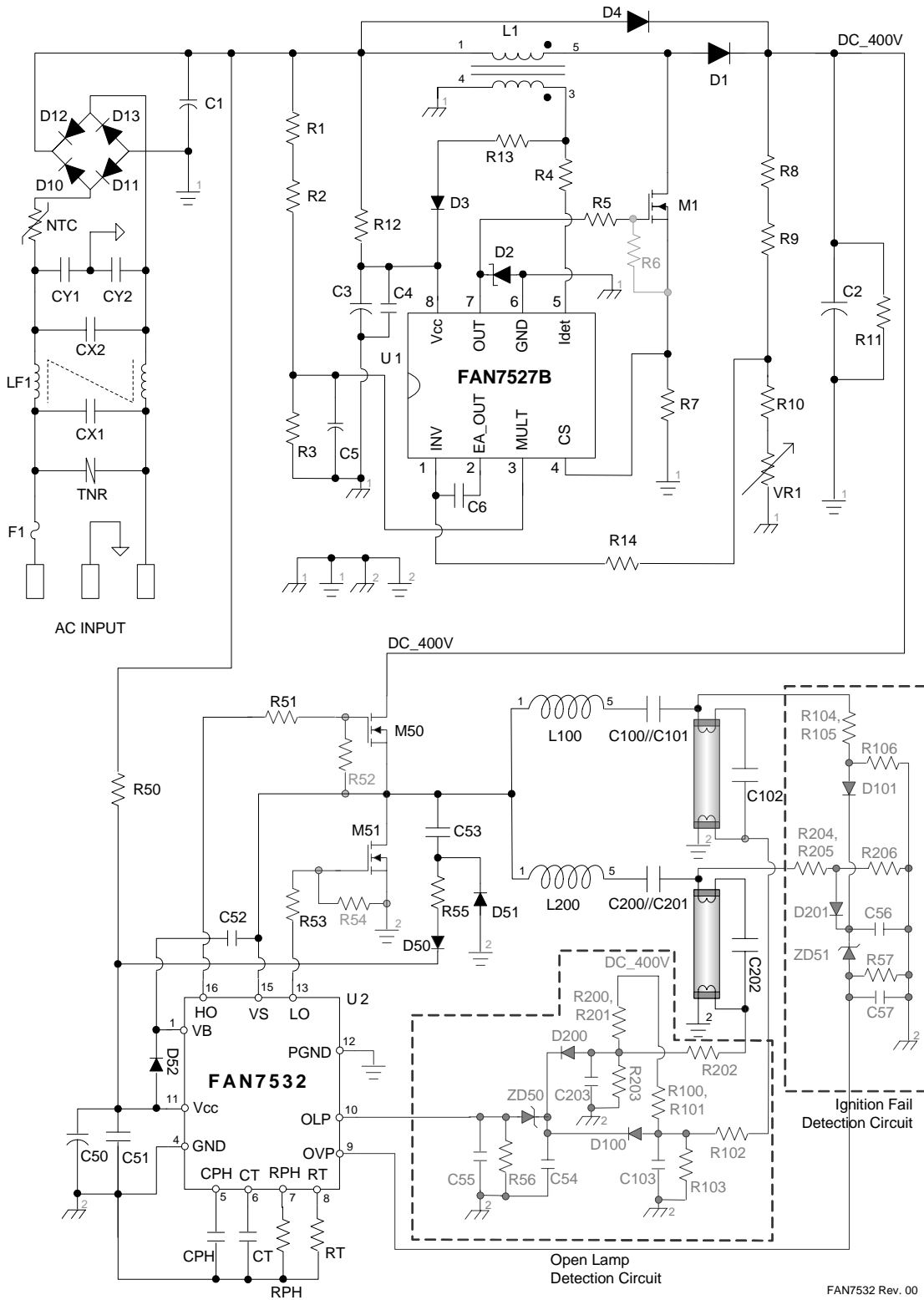

Figure 1. Application Circuit

Internal Block Diagram

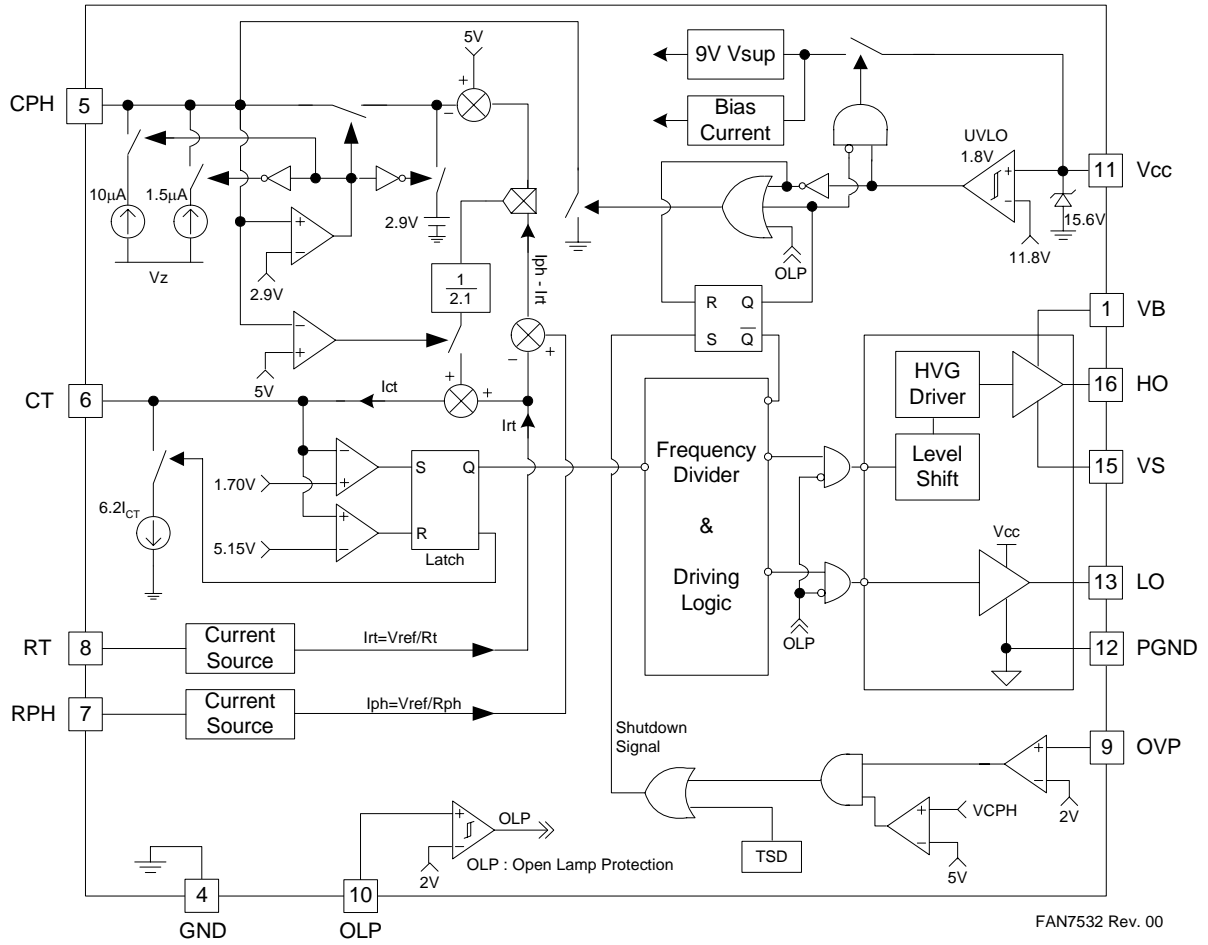
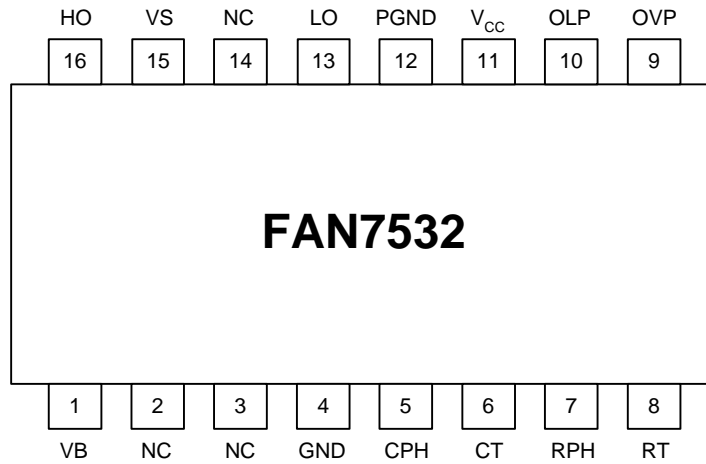

Figure 2. Functional Block Diagram of FAN7532

## Pin Configuration



FAN7532 Rev. 00

**Figure 3. Pin Configuration (Top View)**

## Pin Definitions

Pin Number	Pin Name	Pin Function Description
1	VB	High-Side Floating Supply Voltage
2	N.C.	No Connection
3	N.C.	No Connection
4	GND	Ground
5	CPH	Preheat Time Set Capacitor
6	CT	Oscillator Frequency Set Capacitor
7	RPH	Preheat Frequency Set Resistor
8	RT	Oscillator Frequency Set Resistor
9	OVP	Over-Voltage Protection, Latch Mode
10	OLP	Open Lamp Protection, Only Output Disable Mode
11	V <sub>CC</sub>	Supply Voltage
12	PGND	Power Ground
13	LO	Low-Side Gate Driver Output
14	N.C.	No Connection
15	VS	High-Side Floating Supply Return
16	HO	High-Side Gate Driver Output

## Absolute Maximum Ratings

The "Absolute Maximum Ratings" are those values beyond which the safety of the device cannot be guaranteed. The device should not be operated at these limits. The parametric values defined in the Electrical Characteristics tables are not guaranteed at the absolute maximum ratings. The "Recommended Operating Conditions" table defines the conditions for actual device operation. ( $T_A = 25^\circ\text{C}$ , unless otherwise specified.)

Symbol	Characteristics	Min.	Max.	Unit
$I_{CC}$	Supply Current (See Caution Below)	-	25	mA
$V_S$	High-Side Floating Supply Offset Voltage	$V_B - 25$	$V_B + 0.3$	V
$V_B$	High-Side Floating Supply Voltage	-0.3	625	
$V_{HO}$	High-Side Floating Output Voltage, HO	$V_S - 0.3$	$V_S + 0.3$	
$I_{OH}$	Drive Output Source Current		250	mA
$I_{OL}$	Drive Output Sink Current		500	
$V_{IN}$	CPH, CT, RT, and RPH Pins Input Voltage	-0.3	6	V
$dV_S/dt$	Allowable Offset Voltage Slew Rate	-	50	V/ns
$T_{opr}$	Operating Temperature Range	-25	125	$^\circ\text{C}$
$T_{stg}$	Storage Temperature Range	-65	150	
$P_d$	Power Dissipation	-	0.94	W
$R\theta_{ja}$	Thermal Resistance (Junction-to-Air)	-	100	$^\circ\text{C}/\text{W}$

### Caution:

You must not supply a low-impedance voltage source to the internal clamping zener diode that is between the GND and the  $V_{CC}$  pin of this device.

## Recommended Operating Conditions

Symbol	Parameter	Value	Unit
$V_{CC}$	Supply Voltage	11 to $V_{CL}$	V
$V_S$	High-Side Floating Offset Supply Voltage	600	V
$V_B$	High-Side Floating Supply Voltage	$V_S + 11$ to $V_S + 20$	V
$V_{HO}$	High-Side Floating Output Voltage, HO	$V_S$ to $V_B$	V

## Temperature Characteristics ( $-25^\circ\text{C} \leq T_A \leq 125^\circ\text{C}$ )

Symbol	Parameter	Value	Unit
$\Delta f_{os}$ (Typ)	Temperature Stability for Operating Frequency (fos)	3	%

## ESD Level

Parameter	Pins	Conditions	Level	Unit
Human Body Model (HBM)	GND, CPH, CT, RPH, RT, OVP, OLP, LO	$R = 1.5\text{k}\Omega$ , $C = 100\text{pF}$	$\pm 1000$	V
	VB, VS, HO			
Machine Model (MM)	LO	$C = 200\text{pF}$	$\pm 250$	

### Note:

ESD immunity for all pins, except for condition noted above, is guaranteed up to 2000V (Human Body Model) and 300V (Machine Model).

## Electrical Characteristics

$V_{CC}=V_{BS}=14V$ ,  $T_A=25^\circ C$  unless otherwise specified.

Symbol	Characteristics	Test Condition	Min.	Typ.	Max.	Unit
<b>SUPPLY VOLTAGE SECTION</b>						
$V_{TH(st)}$	Start Threshold Voltage	$V_{CC}$ Increasing	11	11.8	12.6	V
$HY(st)$	UVLO Hysteresis		0.8	1.8	2.8	V
$V_{CL}$	Supply Clamping Voltage	$I_{CC} = 12mA$	14.7	15.6	16.5	V
$I_{ST}$	Start-Up Supply Current	$V_{CC} = 10V$	-	120	180	$\mu A$
$I_{CC}$	Operating Supply Current	Output Not Switching	-	6.4	9.5	mA
$I_{DCC}$	Dynamic Operating Supply Current: ( $I_{CC}+I_{QBS}$ )	50kHz, $C_L = 1nF$	-	8.2	10.5	mA
<b>OSCILLATOR SECTION</b>						
$I_{CPHL}$	CPH Pin Charging Current 1	$V_{CPH} = 2V$	1	1.5	2	$\mu A$
$I_{CPHH}$	CPH Pin Charging Current 2	$V_{CPH} = 4V$	7.7	10	12.3	$\mu A$
$V_{CLAMP}$	CPH Pin Clamp Voltage		5.1	5.65	6.2	V
$f_{PH}$	Preheating Frequency	$V_{CPH} = 0V$ , $R_{PH} = 20k\Omega$ , $C_T = 1nF$	75	85	95	kHz
$t_{PD}$	Preheating Dead Time	$V_{CPH} = 0V$ , $R_{PH} = 20k\Omega$ , $C_T = 1nF$	0.75	1.20	1.55	$\mu s$
$f_{OSC}$	Operating Frequency	$V_{CPH} = Open$ , $R_T = 18k\Omega$ , $C_T = 1nF$	48	50	52	kHz
$t_{OD}$	Operating Dead Time	$V_{CPH} = Open$ , $R_T = 18k\Omega$ , $C_T = 1nF$	1.5	2	2.3	$\mu s$
$\Delta V_{CT}$	Differential Threshold Voltage on CT		3	3.45	4	V
$I_{ch}$	CT Charging Current	$V_{CT} = 1.5V$	400	460	510	$\mu A$
$I_{disch}$	CT Discharging Current	$V_{CT} = 5.5V$	1.95	2.4	2.8	mA
$\Delta f/\Delta V$	Voltage Stability	$12.7V \leq V_{CC} \leq V_{CL}$	-	-	3	%
<b>OUTPUT SECTION</b>						
$I_{LO1}$	Low-Side Driver Source Current	$V_{LO} = V_{CC}$	200	250	-	mA
$I_{LO2}$	Low-Side Driver Sink Current	$V_{LO} = GND$	400	500	-	mA
$I_{HO1}$	High-Side Driver Source Current	$V_{HO} = V_B$	200	250	-	mA
$I_{HO2}$	High-Side Driver Sink Current	$V_{HO} = V_S$	400	500	-	mA
$t_r$	High/Low-Side Rising Time	$C_L = 1nF$	-	90	150	ns
$t_f$	High/Low-Side Falling Time	$C_L = 1nF$	-	40	100	ns
<b>HIGH-VOLTAGE SECTION</b>						
$I_{LK}$	Offset Supply Leakage Current	$V_B = V_S = 600V$	-	-	10	$\mu A$
$I_{QBS}$	Quiescent $V_{BS}$ Supply Current		10	48	90	$\mu A$
<b>PROTECTION SECTION</b>						
$V_{th\_com}$	OVP/OLP Comparator Threshold Voltage		1.8	2	2.3	V
$V_{hy\_com}$	OLP Comparator Hysteresis Voltage		0.6	0.92	1.3	V
$I_{latch}$	Latch Mode Quiescent Current		-	0.35	0.45	mA
$T_{SD}$	Thermal Shutdown Junction Temperature		-	150	-	$^\circ C$

### Typical Performance Characteristics

These characteristic graphs are normalized at  $T_A = 25^\circ\text{C}$ .

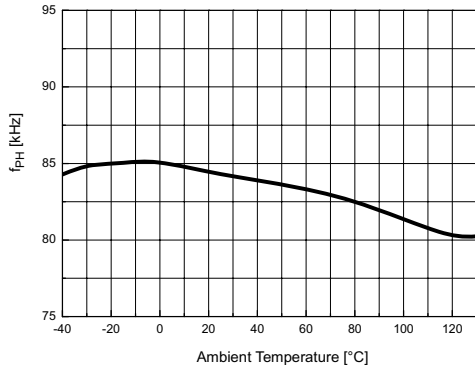

Figure 4. Preheating Frequency vs. Temp.

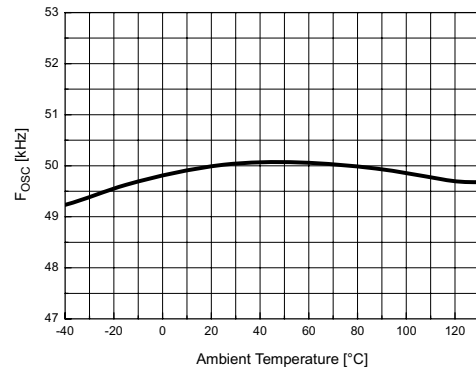

Figure 5. Operating Frequency vs. Temp.

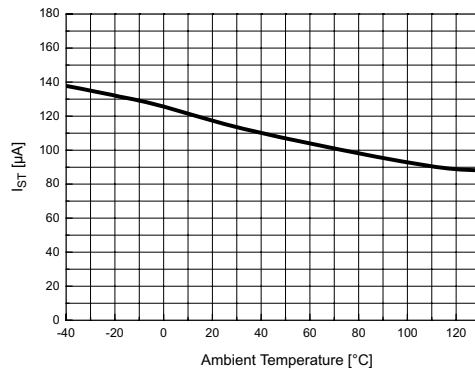

Figure 6. Turn-off Propagation Delay vs. Temp.

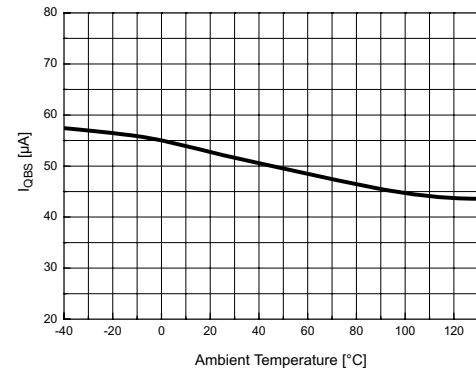

Figure 7. Dynamic Operating Current vs. Temp.

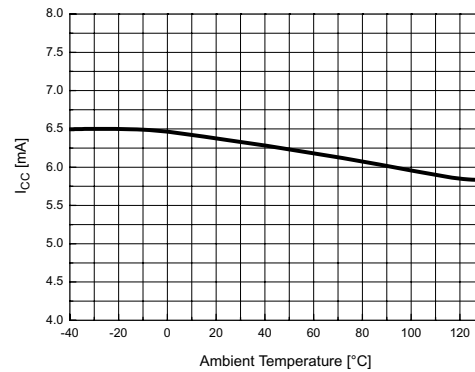

Figure 8. Dynamic Operating Current vs. Temp.

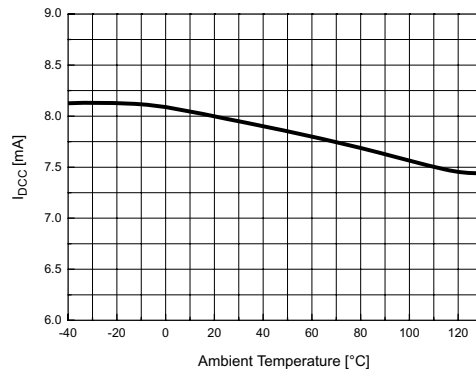
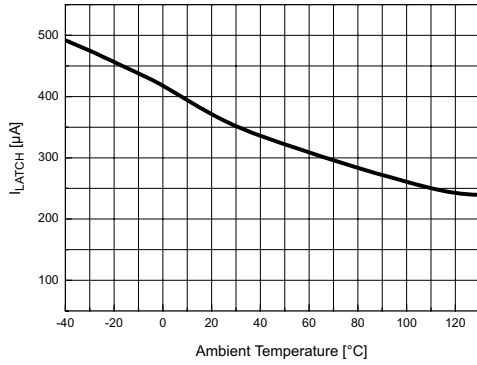

Figure 9. Dynamic Operating Current vs. Temp.

**Typical Performance Characteristics** (Continued)

These characteristic graphs are normalized at  $T_A = 25^\circ\text{C}$ .



**Figure 10. Latch Mode Current vs. Temp.**

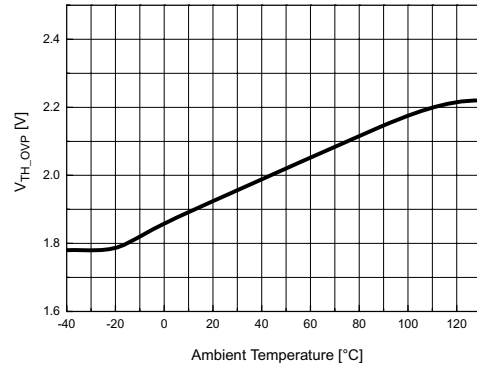

**Figure 11. OVP Detection Voltage vs. Temp.**

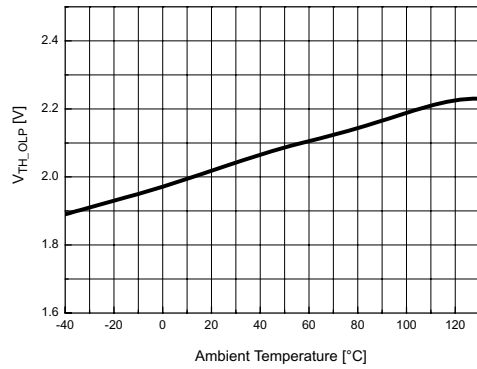

**Figure 12. OLP Detection Voltage vs. Temp.**

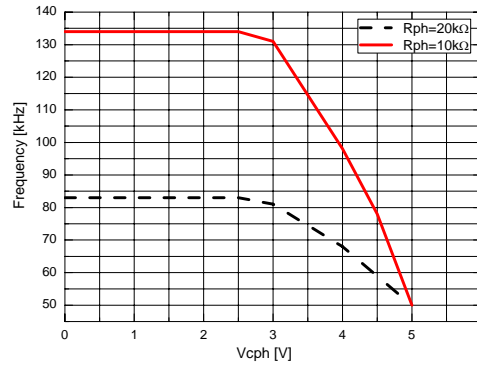

**Figure 13. Preheating Frequency vs. Rph**

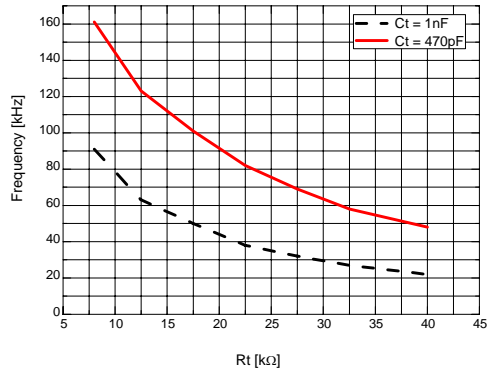

**Figure 14. Run Frequency vs.  $R_t$  and  $C_t$**



## Application Information

### 1. Start-up Circuit

The start-up current is supplied to the IC through the start-up resistor (R<sub>st</sub>). To reduce the power dissipation in R<sub>st</sub>, R<sub>st</sub> is connected to the full-wave, rectified output voltage. The size of R<sub>st</sub> can be determined by equations (1) and (2).

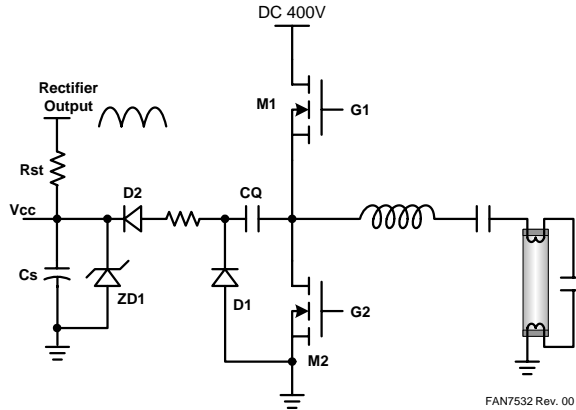

Figure 15. Start-up Circuit

$$R_{st} = \frac{V_{in(ac)} \times \sqrt{2} - V_{th(st),max}}{I_{st,max}} \quad (1)$$

$$= \frac{85 \times \sqrt{2} - 12.4}{0.18 \times 10^{-3}} = 599 [k\Omega]$$

$$R_{st} = \frac{(V_{in(ac,max)} \times \sqrt{2} - V_{cc})^2}{R_{st}} \leq 0.5 [W] \quad (2)$$

$$R_{st} \geq 2 \times (V_{in(ac,max)} \times \sqrt{2} - V_{cc})^2$$

$$\geq 260 [k\Omega]$$

$$\therefore 260 [k\Omega] \leq R_{st} \leq 599 [k\Omega]$$

The size of supply capacitor (Cs) is normally determined by the start-up time and the operating current which is built up by the auxiliary operating current source. The turn-off snubber capacitor (CQ) and two diodes (D1, D2) constitute the auxiliary operating current source for the IC. The charging current through the CQ flows into the IC and charges the supply capacitor. If the size of CQ is increased, the V<sub>CC</sub> voltage on the Cs is also increased.

### 2. Under-Voltage Lockout (UVLO)

The UVLO mode of the FAN7532 is designed to maintain an ultra low supply current of less than 120μA, and to guarantee that the IC is fully functional before two output drivers are activated.

### 3. Oscillator

The gate drive output frequency is half that of the triangular waveform on timing capacitor (CT) at pin #6. In normal operating mode, the timing capacitor charging current is  $4 \cdot I_{rt}$  ( $=V_{ref}/RT$ ). The discharging current is 6.2 times the charging current. During the charging period of the timing capacitor (CT), the MOSFET alternatively turns on. During the discharging period of the timing capacitor (CT), both MOSFETs are off.

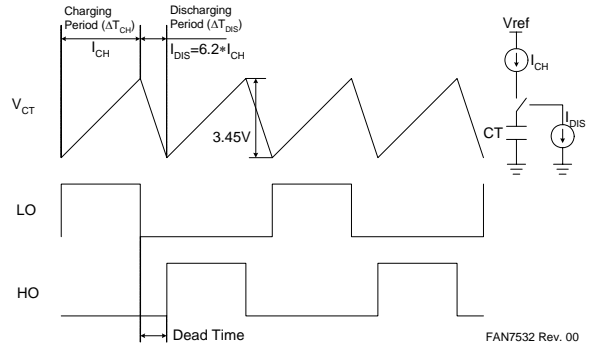

Figure 16. CT & Output Waveforms

The FAN7532 has three operating modes according to V<sub>CPH</sub>, as shown in Figure 17.

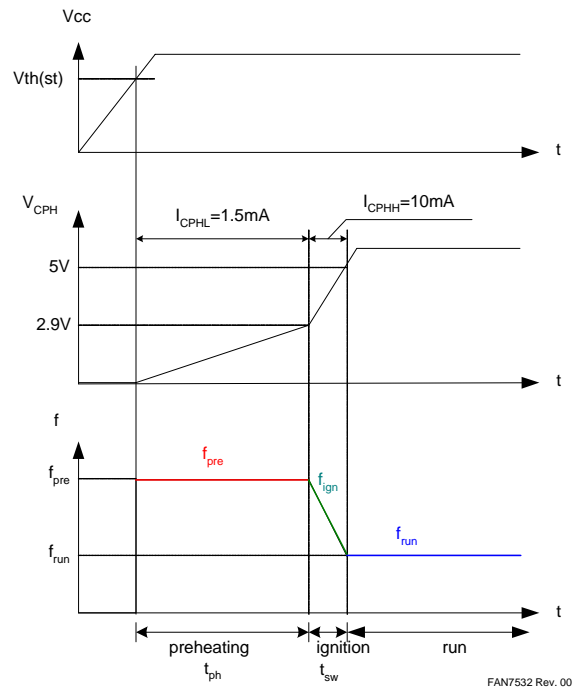

Figure 17. Operating Modes

$0V \leq V_{CPH} \leq 2.9V$ , ;Preheating Frequency

$$I_{CT} = I_{RT} + \frac{I_{PH} - I_{RT}}{(5V - 2.9V)}(5V - 2.9V) = I_{PH}$$

$2.9V \leq V_{CPH} \leq 5V$ , ;Ignition Frequency

$$I_{CT} = I_{RT} + \frac{I_{PH} - I_{RT}}{(5V - 2.9V)}(5V - V_{CPH})$$

$V_{CPH} \geq 5V$

$I_{CT} = I_{RT}$ , ;Run Frequency

#### 4. Preheating Mode

The preheating mode is defined as the IC's internal status when the  $V_{CPH}$  is between 0V and 2.9V. During preheating, the current that flows through the ballast circuit heats the lamp filaments. This is necessary for maximizing lamp life and reducing the required ignition voltage. When the  $V_{CC}$  exceeds the UVLO high threshold, the preheating time set-up capacitor, CPH, starts being charged by the internal 1.5μA current source until the  $V_{CPH}$  reaches 2.9V. Until the  $V_{CPH}$  reaches 2.9V, the switching frequency throughout the preheating mode is determined by CT and RPH.

The preheating time is determined by the CPH and the 1.5μA current source. Therefore, the preheating time is determined by equation (3):

$$t_{pre} = CPH \times \frac{V_{CPH}}{I_{charging}} \quad (3)$$

The preheating frequency is determined by the amount of charging and discharging current to the CT capacitor. The charging and discharging current during preheating mode is decided by equation (4):

$$I_{pre\_ch} = 4 \times \frac{V_{ref}}{R_{PH}} \quad (4)$$

$$I_{pre\_disch} = 4 \times \frac{(6.25 \times V_{ref})}{R_{PH}}, \quad V_{ref} = 4V \text{ (Constant)}$$

The charging and discharging time of the CT capacitor during preheating mode is decided by equation (5):

$$t_{pre\_ch} = C_T \times \frac{dV_{CT}}{I_{pre\_ch}} \quad (5)$$

$$t_{pre\_disch} = C_T \times \frac{dV_{CT}}{I_{pre\_disch}}, \quad dV_{CT} = 3.45V \text{ (Constant)}$$

Finally, the FAN7532's preheating frequency in the preheating period is determined by equation (6):

$$f_{pre} = \frac{1}{2 \times (t_{pre\_ch} + t_{pre\_disch})} \quad (6)$$

#### 5. Ignition Mode

The ignition mode is defined as the IC's internal status when  $V_{CPH}$  is approximately between 2.9V and 5V. During ignition, the operating frequency is decreased to a pre-determined value. At the same time, a very high-voltage for igniting the lamp is established across the lamp. When the  $V_{CPH}$  exceeds 2.9V, the FAN7532 enters the ignition mode. Once  $V_{CPH}$  exceeds 5V, the device enters the run mode described in the following section. In the ignition period, the internal 10mA current source charges the external preheating timing capacitor (CPH) to increase noise immunity with the sharp slope of the  $V_{CPH}$ . The ignition time is determined by the CPH and internal 10mA current source ( $\Delta T_{ign} = CPH \times \frac{\Delta V_{CPH}}{I_{CPH}}$ ). In this mode, the switching frequency is determined by CT, RPH, and RT. Therefore, the charging and discharging currents change according to  $V_{CPH}$  and are determined by equation (7).

$$I_{CT} = I_{RT} + \frac{I_{PH} - I_{RT}}{(5V - 2.9V)}(5V - V_{CPH}) \quad (7)$$

#### 6. Run Mode

After the lamp has successfully ignited, the FAN7532 enters run mode. The run mode is defined as the IC's internal status when  $V_{CPH}$  is higher than 5V. In this mode, the lamp is being driven with a normal power level after the lamp is discharged. The run mode switching frequency is determined by the timing resistor RT and the timing capacitor CT. When the  $V_{CPH}$  exceeds 5V, the protection-masking mode is disabled and the IC can enter the protection mode. The running frequency is determined by the amount of charging and discharging current to CT capacitor.

The charging and discharging currents during preheating mode are decided by the equation (8):

$$I_{run\_ch} = 2 \times \frac{V_{ref}}{R_T} \quad (8)$$

$$I_{run\_disch} = 2 \times \frac{(6.25 \times V_{ref})}{R_T}, \quad V_{ref} = 4V \text{ (Constant)}$$

$$t_{run\_ch} = C_T \times \frac{dV_{CT}}{I_{run\_ch}} \quad (9)$$

$$t_{run\_disch} = C_T \times \frac{dV_{CT}}{I_{run\_disch}}, \quad dV_{CT} = 3.45V \text{ (Constant)}$$

Finally, the preheating frequency in the preheating period using the FAN7532 is determined by the equation (10):

$$f_{run} = \frac{1}{2 \times (t_{run\_ch} + t_{run\_disch})} \quad (10)$$

### 7. Protection Modes

The FAN7532 has two types of protection modes.

#### 1) Over-Voltage Protection (OVP) Mode

The OVP pin is normally connected to the external components that detect lamp voltage between a lamp's cathodes. This voltage is always maintained under 2V in normal operation. If the lamp enters the end-lamp-life or abnormal condition, the lamp does not turn-on even if there is enough voltage supplied between two cathodes. Normally, this condition means that one of the cathodes

is broken, deactivated, or the lamp is deeply blackened around the cathodes. In this state, the ballast constantly generates very high voltage between two cathodes to ignite according to a specific procedure in the control IC. When the voltage of OVP pin exceeds 2V, the IC instantly enters the protection mode. To exit this mode, the  $V_{CC}$  must be recycled below the UVLO low threshold.

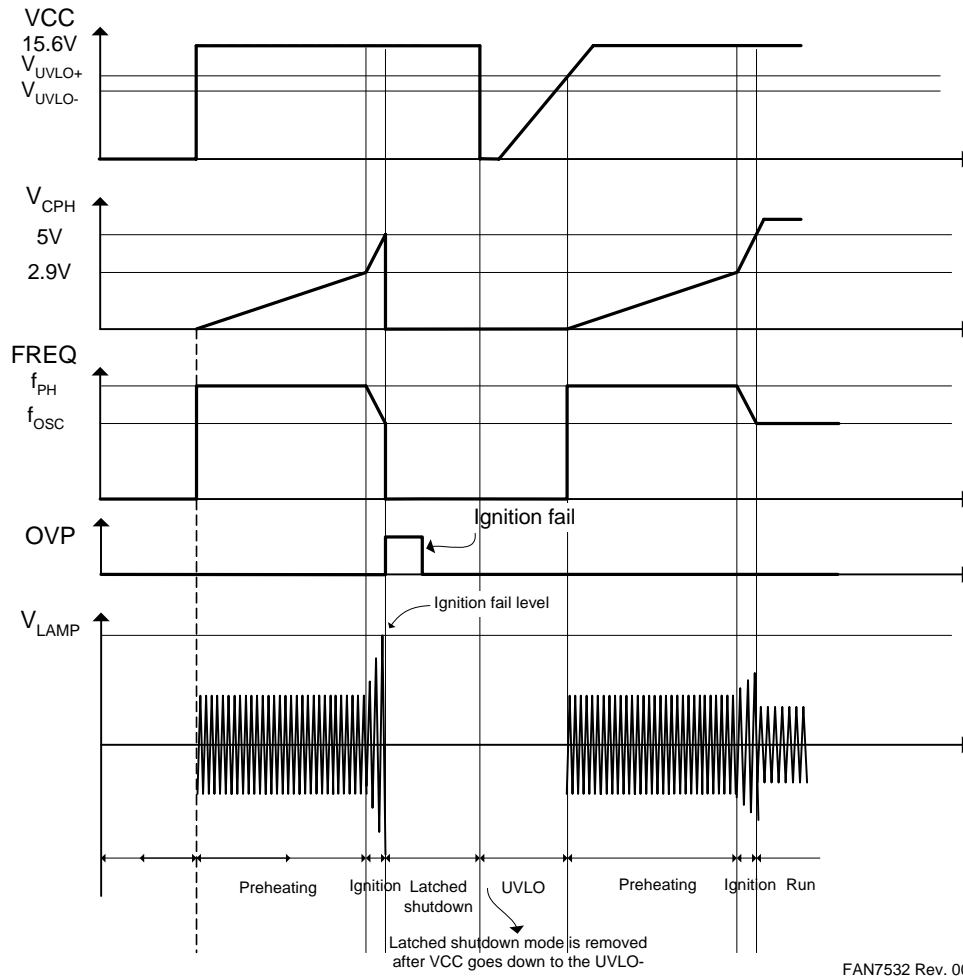

FAN7532 Rev. 00

Figure 18. Timing Diagram (OVP Mode)

## 2) Open Lamp Protection (OLP) Mode

After the lamp has successfully ignited, the FAN7532 enters run mode. In this mode, if one of the cathodes isn't correctly connected to the ballast, the ballast stops operation for safety until the lamp is changed and a new one is connected between the lamp and the ballast. As soon as the voltage of OLP pin exceeds 2V, the IC

enters the protection mode. However, the FAN7532 outputs are only disabled in this mode. To exit protection mode, the lamp must be replaced or correctly connected to the ballast.

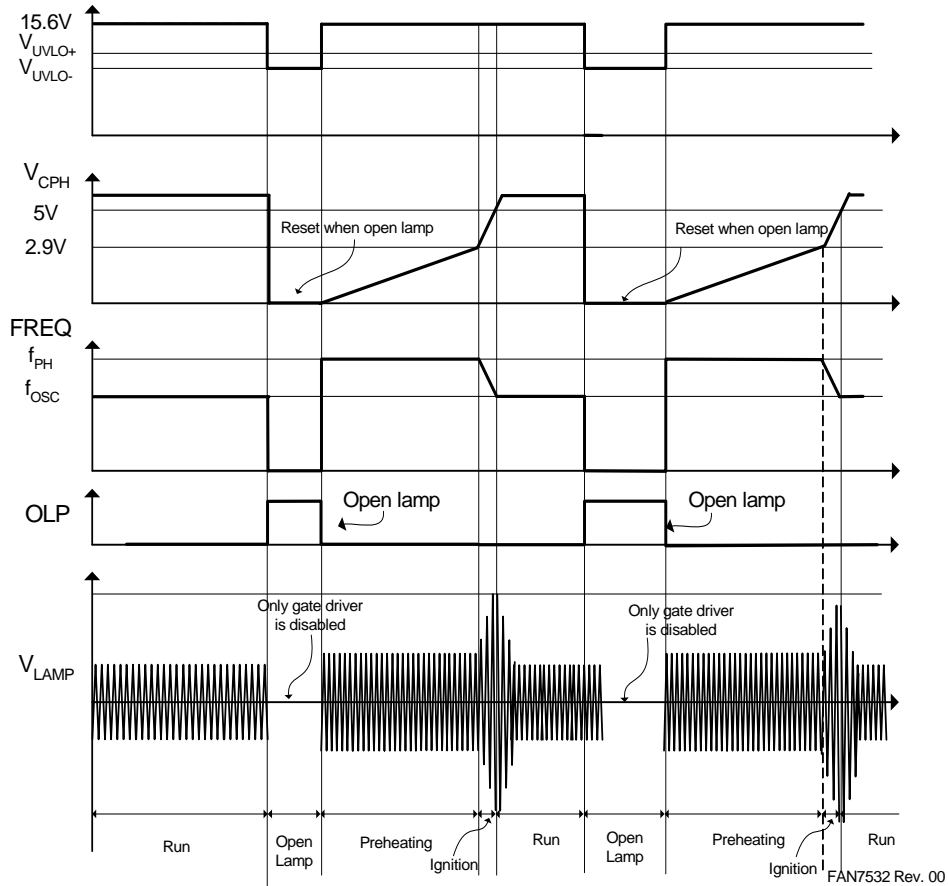

Figure 19. Timing Diagram (OLP Mode)

## 8. PCB Layout Guides

Component selection and placement on the PCB is very important when using power control ICs. Bypass the  $V_{CC}$  to GND as close to the IC terminals as possible with a low ESR/ESL capacitor, as shown in Figure 20. This bypassed capacitor can reduce the noise from the power supply parts, such as a startup resistor and a charge pump. The GND lead should be directly connected to the low-side power MOSFET using an individual PCB trace. In addition, the ground return path of the timing components (CPH, CT, RPH, RT) and  $V_{CC}$  decoupling capacitor should be connected directly to the IC GND lead and not via separate traces or jumpers to other ground traces on the board. These connection techniques prevent high-current ground loops from interfering with sensitive timing component operations and allow the entire control

circuit to reduce common-mode noise due to output switching.

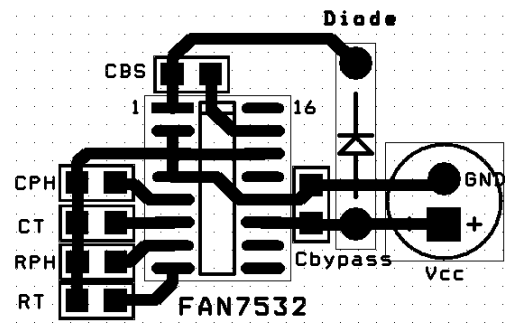

Figure 20. PCB Layout

## Components List

(for Wide-Range 32W× 2 Lamps Application)

Part number	Value	Note	Manufacturer
<b>INPUT PART</b>			
F1	250V, 3A	Fuse	
CX1	47nF, 275Vac	Box-Cap	
CX2	150nF, 275Vac	Box-Cap	
CY1, CY2	2200pF, 3000V	Y-Cap	
TNR	470V	471	
NTC	10Ω	10D09	
D10, D11, D12, D13	400V, 1A	1N4004	Fairchild Semiconductor
LF1	45mH		
<b>PFC PART</b>			
R1, R2, R8	910kΩ	Ceramic, 1206	
R3	22kΩ	Ceramic, 1206	
R4	22kΩ	Ceramic, 1206	
R5	10Ω	Ceramic, 1206	
R6	22kΩ	Ceramic, 1206	
R7	0.47Ω	1W	
R9	100kΩ	Ceramic, 1206	
R10	2.2kΩ	Ceramic, 1206	
R11	220kΩ	1W	
R12	150kΩ	1W	
R13	4.7Ω	Ceramic, 1206	
R14	0Ω	Ceramic, 1206	
VR1	10kΩ	Variable Resistor	
C1	0.22μF, 630V	Mylar-Cap	
C2	47μF, 450V	Electrolytic	
C3	10μF, 50V	Electrolytic	
C4	105	Ceramic, 0805	
C5	102	Ceramic, 0805	
C6	105	Ceramic, 0805	
L1	0.9mH (80T:6T)	EI2820	
D1, D4	600V, 1A, Ultrafast	UF4005	Fairchild Semiconductor
D2	Schottky Diode	MBR0540	Fairchild Semiconductor
D3	Small Signal Diode	FDLL4148	Fairchild Semiconductor
M1	500V, 6A, Power MOSFET	FQP6N50C, FQPF6N50C	Fairchild Semiconductor
U1	PFC IC	FAN7527B	Fairchild Semiconductor

**Components List** (Continued)

Part number	Value	Note	Manufacturer
<b>BALLAST PART</b>			
R50	390k $\Omega$	1W	
R51, R53	39 $\Omega$	Ceramic, 1206	
R52, R54	47k $\Omega$	Ceramic, 1206	
R55	5.6 $\Omega$	1W	
R56, R57	68k $\Omega$	Ceramic, 0805	
RPH	27k $\Omega$	Ceramic, 1206, 1%	
RT	18k $\Omega$	Ceramic, 1206, 1%	
R100, R104, R200, R204	910k $\Omega$	Ceramic, 1206	
R101, R105, R201, R205	300k $\Omega$	Ceramic, 1206	
R102, R202	5.1k $\Omega$	Ceramic, 1206	
R103, R203	68k $\Omega$	Ceramic, 1206	
R106, R206	30k $\Omega$	Ceramic, 1206	
C50	10 $\mu$ F, 50V	Electrolytic	
C51	105	Ceramic, 0805	
C52	104	Ceramic, 1206	
C53	681, 630V	Miller-Cap	
C54, C55, C56, C57, C103, C203	104	Ceramic, 0805	
CT	1nF	Ceramic, 0805, 5%	
CPH	680nF	Ceramic, 0805	
C100, C101, C200, C201	6.8nF, 630V	Mylar-Cap	
C102, C202	3.3nF, 1000V	Mylar-Cap	
L100, L200	3.2mH (120T)	EE2820	
M50, M51	500V, 5A, Power MOSFET	FQP5N50C, FQPF5N50C	Fairchild Semiconductor
ZD50, ZD51	Zener Diode	1N5245	Fairchild Semiconductor
D50, D51, D52	600V, 1A, Ultrafast	UF4005	Fairchild Semiconductor
D100, D101, D200, D201	Small Signal Diode	FDLL4148	Fairchild Semiconductor
U2	Ballast IC	FAN7532	Fairchild Semiconductor

# Package Dimensions

## 16-SOP

Dimensions in millimeters

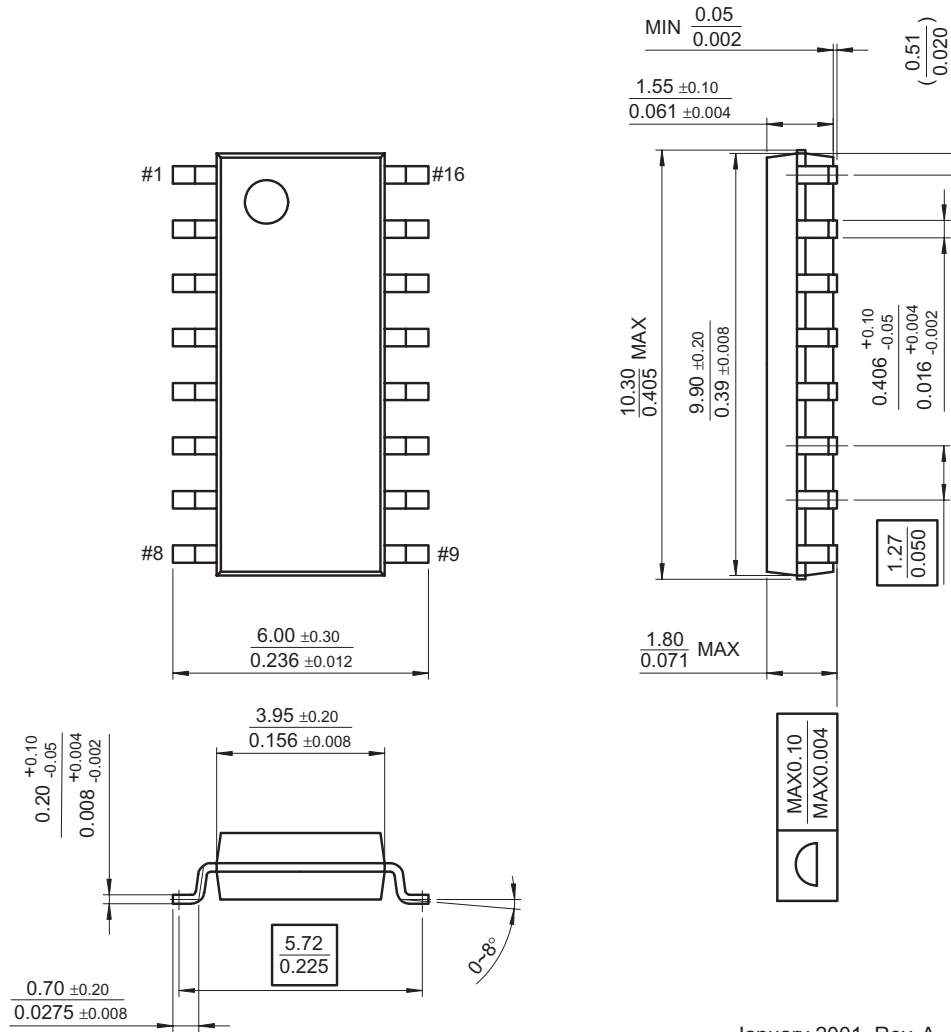
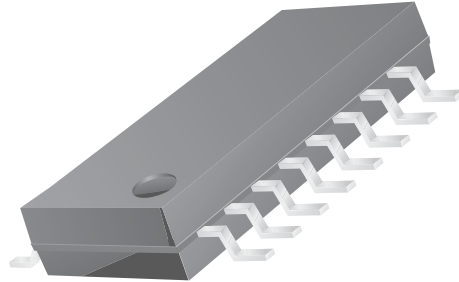

January 2001, Rev. A

**TRADEMARKS**

The following are registered and unregistered trademarks Fairchild Semiconductor owns or is authorized to use and is not intended to be an exhaustive list of all such trademarks.

ACEx™	FAST®	ISOPLANAR™	PowerEdge™	SuperFET™
ActiveArray™	FASTr™	LittleFET™	PowerSaver™	SuperSOT™-3
Bottomless™	FPST™	MICROCOUPLER™	PowerTrench®	SuperSOT™-6
Build it Now™	FRFET™	MicroFET™	QFET®	SuperSOT™-8
CoolFET™	GlobalOptoisolator™	MicroPak™	QS™	SyncFET™
CROSSVOLT™	GTO™	MICROWIRE™	QT Optoelectronics™	TCM™
DOME™	HiSeC™	MSX™	Quiet Series™	TinyLogic®
EcoSPARK™	I <sup>2</sup> C™	MSXPro™	RapidConfigure™	TINYOPTO™
E <sup>2</sup> C MOS™	i-Lo™	OCX™	RapidConnect™	TruTranslation™
EnSigna™	ImpliedDisconnect™	OCXPro™	µSerDes™	UHC™
FACT™	IntelliMAX™	OPTOLOGIC®	ScalarPump™	UniFET™
FACT Quiet Series™		OPTOPLANAR™	SILENT SWITCHER®	UltraFET®
Across the board. Around the world.™		PACMAN™	SMART START™	VCX™
The Power Franchise®		POP™	SPM™	Wire™
Programmable Active Droop™		Power247™	Stealth™	

**DISCLAIMER**

FAIRCHILD SEMICONDUCTOR RESERVES THE RIGHT TO MAKE CHANGES WITHOUT FURTHER NOTICE TO ANY PRODUCTS HEREIN TO IMPROVE RELIABILITY, FUNCTION, OR DESIGN. FAIRCHILD DOES NOT ASSUME ANY LIABILITY ARISING OUT OF THE APPLICATION OR USE OF ANY PRODUCT OR CIRCUIT DESCRIBED HEREIN; NEITHER DOES IT CONVEY ANY LICENSE UNDER ITS PATENT RIGHTS, NOR THE RIGHTS OF OTHERS. THESE SPECIFICATIONS DO NOT EXPAND THE TERMS OF FAIRCHILD'S WORLDWIDE TERMS AND CONDITIONS, SPECIFICALLY THE WARRANTY THEREIN, WHICH COVERS THESE PRODUCTS.

**LIFE SUPPORT POLICY**

FAIRCHILD'S PRODUCTS ARE NOT AUTHORIZED FOR USE AS CRITICAL COMPONENTS IN LIFE SUPPORT DEVICES OR SYSTEMS WITHOUT THE EXPRESS WRITTEN APPROVAL OF FAIRCHILD SEMICONDUCTOR CORPORATION.

As used herein:

- Life support devices or systems are devices or systems which, (a) are intended for surgical implant into the body, or (b) support or sustain life, or (c) whose failure to perform when properly used in accordance with instructions for use provided in the labeling, can be reasonably expected to result in significant injury to the user.
- A critical component is any component of a life support device or system whose failure to perform can be reasonably expected to cause the failure of the life support device or system, or to affect its safety or effectiveness.

**PRODUCT STATUS DEFINITIONS**

Definition of Terms

Datasheet Identification	Product Status	Definition
Advance Information	Formative or In Design	This datasheet contains the design specifications for product development. Specifications may change in any manner without notice.
Preliminary	First Production	This datasheet contains preliminary data, and supplementary data will be published at a later date. Fairchild Semiconductor reserves the right to make changes at any time without notice to improve design.
No Identification Needed	Full Production	This datasheet contains final specifications. Fairchild Semiconductor reserves the right to make changes at any time without notice to improve design.
Obsolete	Not In Production	This datasheet contains specifications on a product that has been discontinued by Fairchild semiconductor. The datasheet is printed for reference information only.